



Low temperature bath/circulator

R4R

Operating Manual

If you have any feedback on Grant's products or services, we would like to hear from you.
Please send all feedback to:

Quality Manager
Grant Instruments (Cambridge) Ltd
Evolution House
Unit 2, Durham Way
Royston Gateway
Royston
SG8 5GX
UK

Tel: +44 (0) 1763 260 811
E-mail: support@grantinstruments.com

Sales
Tel: +44 (0) 1763 264 741
E-mail: salesdesk@grantinstruments.com

Representative in the European Union

Grant Instruments Europe B.V.
Strawinskylaan 411
WTC, Tower A 4th Floor
1077 XX AMSTERDAM
THE NETHERLANDS

Email: grant@eu.grantinstruments.com

Contents

Contents	2
1.0 Use of products	3
2.0 How to use this operating manual	3
3.0 Safety information	3
3.1 Safety compliance	3
3.2 Safety symbols	3
3.3 Safety warnings	4
4.0 Operating instructions	5
4.1 Unpacking instructions	5
4.2 Fitting the controller to the equipment	5
4.3 Internal tray	5
4.4 Recommended liquids	6
4.5 Installation	7
4.6 Electrical supply	7
5.0 Operating procedures	8
5.1 Operation	8
5.1.1 Liquid level	8
5.1.2 Operation above 60°C	8
5.1.3 Setting the over-temperature thermostat	8
5.1.3 Using the control unit pump	9
5.1.4 Emptying the R4R	9
5.1.5 Setting up and switching on	9
5.2 Using the equipment	11
5.2.1 Product description, refrigeration unit front panel (grille removed)	11
5.2.2 Refrigeration, rear panels	12
5.2.3 Using the Optima heating circulator	12
6.0 Technical specifications	13
6.1 Operating conditions	13
6.2 Electrical details	13
6.3 Specification	13
7.0 Technical Tips	14
7.1 Which water should you use in your equipment tank?	14
7.2 How to prevent rust in equipment tanks	14
7.3 How to prevent algae and bacteria?	14
8.0 Warranty information	15
9.0 Maintenance and service	15
9.1 Routine maintenance	15
9.2 Cleaning	16
9.3 Fuses	16
9.5 Routine safety tests	17
9.7 Service	17
10.0 Optional accessories	18
10.1 Alternative pump	18
11.0 Troubleshooting	18
12.0 Contact Grant Instruments	19
13.0 Compliance	19

1.0 Use of products

The following products are covered by this operating manual:

- R4R

The product listed above is a low temperature circulator designed for indoor laboratory use by a professional user.

Grant R series low temperature baths/circulators (*the equipment*) are designed to be used with a Grant Optima™ heating circulator (referred to as Optima unit in text). They provide a source of cooling for many sensitive analytical procedures. Applications requiring the precision temperature control of samples include spectrophotometry, viscometry, refractrometry and electrophoresis. Grant's range of more powerful chillers are ideally suited for applications requiring the removal of the mechanical or electrical heat produced in apparatus or machinery, combined with a higher pressure flow for faster heat removal within restricted systems.

2.0 How to use this operating manual

This operating manual will allow you to unpack, set-up and operate the equipment correctly and safely. Important safety information, symbols and warnings are listed below and should be read carefully. Section 4 gives information about how to unpack and install the equipment correctly. Section 5 gives provides operating information. Product technical specifications and tips are provided in sections 6 and 7. The warranty for this product is for THREE YEARS and is detailed in section 8 and should be registered by completing the on-line registration form at www.grantinstruments.com.

If there is a technical matter that this operating manual does not address, or any other question concerning this product, please contact Grant Instruments or your local distributor, who will be able to provide any additional information.

3.0 Safety information

3.1 Safety compliance

The Grant R series low temperature bath/circulator meets the requirements of international safety standard IEC 61010: Safety requirements for electrical equipment for measurement, control, and laboratory use.

3.2 Safety symbols

The symbols below are marked on the equipment and throughout this manual to indicate:



Caution: Surface(s) and heat transfer liquid can be hot during and after use.



Read these instructions before installation or use of the equipment



Warning, hazard: read these instructions before proceeding to ensure you understand the nature of the hazard.



Warning: equipment contains a flammable refrigerant.

3.3 Safety warnings



Use only as specified by the operating instructions: if the equipment is used in a manner not specified by the manufacturer, the protection provided by the equipment may be impaired.



This equipment is only for indoor use by or supervised by a professional user.



Use only water, water-glycol, or silicone oil with this equipment (see section 4.7 for more details). Do not inhale the vapours given off as they may be toxic. Liquids should be safely discarded and replaced.



Make sure the correct fluid type has been selected in the heating circulator and ensure that the fluid is only used within its specified temperature range.



Do not use the equipment with any sample material that could cause a fire or any other kind of hazard.



Do not use the equipment in an area where there are aggressive or explosive chemical mixtures.



It is the user organisation's responsibility to carry out appropriate decontamination if hazardous material is spilt on the equipment.



Before moving, disconnect from the mains power supply.



If a warning message or warning light appears on the heating circulator display, do not touch the liquid or the tank, they may be very hot.



Do not touch surfaces which become hot during high temperature operation.



It is the user organisation's responsibility to carry out a risk assessment when operating this product within their operating environment.



WARNING: Do not use mechanical devices or other means to accelerate defrosting: either turn the equipment off or set it to ambient temperature and wait until all the ice has melted.



WARNING: Do not damage the refrigerant circuit.

4.0 Operating instructions

4.1 Unpacking instructions

Standard equipment includes:

- R4R refrigeration unit with lid
- Communications cable
- Mains cord with plug
- Operating manual



R4R refrigeration unit weighs 40kg. Take necessary precautions when moving and lifting.

Remove packing materials carefully and retain them for future shipment or storage of the equipment.

4.2 Fitting the controller to the equipment

The Optima unit can be fitted in two orientations on the R unit facing over the tank opening or outwards

1. Remove the bridge plate from the R unit tank by unscrewing the four black thumb screws.
2. Fit the Optima unit through the hole in the bridge plate and align using the locating threads. Secure using the retaining nuts. Hand tighten only.
3. Re-attach the bridge plate onto the R unit, using the retained black thumb screws.

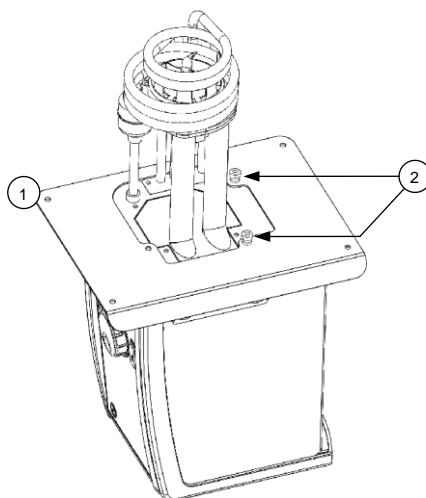

4.3 Internal tray

The equipment fluid tank is fitted with an internal tray which covers the cooling coils. This aids fluid circulation and fluid temperature stability. It also protects any items placed in the tank. Ensure this is in place before operating the bath.

The tray can be removed for cleaning. Always replace after cleaning.

4.4 Recommended liquids

The following table lists the recommended liquids for different temperature ranges. Always ensure the liquid used is safe and suitable for your working temperature. If using non-recommended heat transfer liquids, it is the responsibility of the user to conduct an assessment to ensure the intended fluid is compatible with the equipment. If in doubt, please contact the Grant Instruments technical support team.



To ensure protection the over-temperature cut-out must be set appropriately for the heat transfer liquid selected (see table below)



If using non-recommended heat transfer liquids it is important to set the over-temperature cut-out to a value no higher than 25°C below the fire point of the liquid.



Use fume extraction when using silicone fluids at elevated temperatures

Temp range	Recommended liquid	Comments
-50°C to 50°C	Silicone oil – low viscosity	Bayer silicone M3. Follow the manufacturer's instructions. For safe disposal consult your local regulations.
-30°C to 30°C	50% water, 50% antifreeze (inhibited ethylene glycol)	WARNING: Ethylene glycol is toxic – follow the manufacturer's instructions. For safe disposal consult your local regulations. Use a lid to reduce the dilution of the mixture caused by condensing water vapour from the air, and to maintain the cool down rate.
0°C to 30°C	80% water, 20% antifreeze (inhibited ethylene glycol)	
5°C to 99.9°C	Water*	Water can be used but care should be taken above 60°C as hot vapour can be dangerous. Use a lid or polypropylene spheres above 60°C to ensure good performance & reduce evaporation. At temperatures approaching 99°C the temperature performance will be affected due to localised boiling. The units should not be used to boil water.
70°C to 120°C	Silicone fluid Viscosity ~20cs Flash point ≥230°C Fire Point ≥280°C	Dow Corning DC200/20 silicone fluid is a suitable liquid – follow the manufacturer's instructions. For safe disposal consult your local regulations.

* See section 7.1 for further details

4.5 Installation

After transportation, let the equipment stand in its intended working position for six hours. This is to allow the oil to drain to the bottom of the compressor. This is normal procedure for refrigeration compressors.

Allow at least 100mm clearance from obstructions on all sides so that there is free air flow through the unit.



Place the equipment on a firm, level surface. Ensure that the mains plug and the switch at the rear of the equipment are easily accessible.



After transport or storage in humid conditions, always allow the equipment to stand for at least an hour at room temperature before operating.



Do not block or restrict ventilation slots. Allow at least 100mm clearance from obstructions



Do not connect to a power supply or switch on before filling the tank.



Drain before moving the equipment. Liquid to be drained should not be below 10°C or above 50°C.



Always operate the equipment with the condenser grille fitted. Do not touch the condenser fins, they are sharp and may cause injury.

4.6 Electrical supply



Connect the equipment to a grounded (earthed) electrical power supply with voltage and frequency within the range specified on the serial number plate.



The equipment must only be connected to the mains using the mains cord supplied or one with an identical rating (see section 9.4)



Ensure the mains switch and isolating device (power supply connector) are easily accessible during use.

5.0 Operating procedures

5.1 Operation

5.1.1 Liquid level

Fill the tank to an appropriate level with a liquid suitable for your working temperature; see section 4.4 for liquid options. Allow for thermal expansion and contraction of the liquid during operation and for any liquid in external circulation paths. If using liquids that can evaporate then periodic checking and refilling should be completed. The low level float switch will alarm if the liquid level drops below the minimum required level and the unit will switch off the heater and stop temperature control.

5.1.2 Operation above 60°C

A lid or polypropylene spheres must be used above 60°C to maintain temperature control and to ensure that the bath fluid temperature reaches the set point. They will save energy by preventing excessive evaporation and reduce the frequency that the bath needs to be refilled.



Take care when lifting and removing the lid as it may be hot. Steam and hot vapours can cause scalding.

5.1.3 Setting the over-temperature thermostat

An over-temperature cut-out dial with a temperature scale is located at the top right of the heating circulator. The over-temperature probe independently monitors the bath temperature and switches the heater off if it goes above the cut-out threshold.

Coarse setting of the over-temperature thermostat

Rotate the temperature cut-out dial in line with the marked scale to the desired setting. This should be higher than the set temperature to avoid operating the cut-out before the set temperature has been reached.

If the alarm is triggered the sounder can be silenced by pressing either the **F** or **S** button once. To continue to use the heating circulator, let the bath liquid cool by at least 5°C, either naturally or by replacing the liquid, switch the equipment off, wait 10 seconds and switch it on again to clear the alarm. To avoid nuisance tripping the trip point needs to be set at least 5°C above the desired control temperature.

Alternative setting of the over-temperature thermostat

Rotate the temperature cut-out dial to maximum (or at least a value above the level required) and configure the set temperature to the cut-out level required. Leave the bath to reach the set temperature and stabilise for at least 5 minutes. Turn the cut-out dial slowly anticlockwise until an over-temperature fault is displayed on screen and the alarm sounds continuously. This gives an over-temperature trip point at the set temperature. The audible alarm can be cancelled by pressing either the **F** or **S** button once.

To continue to use the heating circulator, let the bath liquid cool by at least 5°C, either naturally or by replacing the liquid, switch the equipment off, wait 10 seconds and switch it on again to clear the alarm. To avoid nuisance tripping the trip point needs to be set at least 5°C above the desired control temperature.

5.1.3 Using the control unit pump

The Optima unit allows liquid to be pumped around a closed external system (not open to the atmosphere). It cannot be used for circulation through an external open tank. The pump is fitted with a blanking plate as standard. Fit a pump connector plate as shown below. Ensure o-rings are located in the grooves, use silicone grease to hold the o-rings in place. Note: the blanking/connector plates have a locating hole (see A below) to assist correct alignment onto the pump moulding. It is important to verify the hole is aligned with the corresponding locating pin (see B below) on the pump moulding. Failure to do so will result in a leaking connection. Retain the blanking plate for refitting when the pump is no longer required.

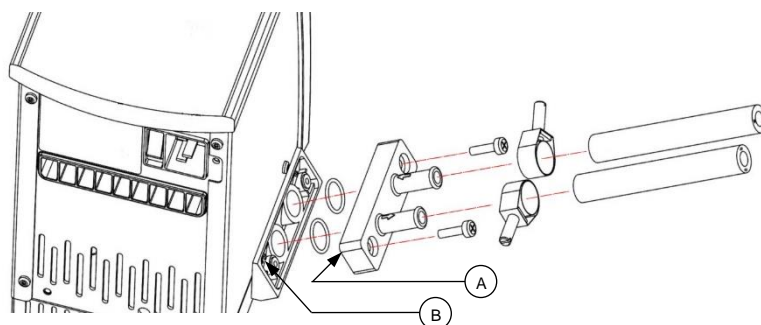

Always use pump connectors and hoses that are suitable for the operating temperature and liquid used. Check the pipe connections are secure.



Never disconnect any pipes or hoses while they contain very hot or very cold liquids or while the Optima unit is pumping.



Never use silicone oil with silicone tubing.

Pumping heat transfer liquid around an external system can lead to hazards that are outside the control of Grant Instruments. It is essential that the user conducts a risk assessment of the entire equipment installation to ensure that correctly rated materials have been used throughout and that the system can be used safely.

5.1.4 Emptying the R4R

The equipment tank should be emptied to a safe level prior to moving. A drain tap is included to allow convenient emptying. See section 5.2.3 for full details.



Allow the liquid temperature to fall below 50°C before emptying.

5.1.5 Setting up and switching on

Follow instructions in section 5.1.4 to attach the pump connector plate and insulated hose. Before filling and switching on, attach the open end of the hose to the application, taking care to note the inlet and outlet.



Ensure all hoses are connected securely. Liquid will begin pumping immediately once the equipment is switched on.

Add the appropriate working liquid to the bath to at least the minimum recommended fill level such that the float level switch is fully raised.

The Optima unit is connected directly to the mains supply with the IEC cable supplied with the Optima unit (230V units only).

Connect the refrigeration unit directly to the mains using the IEC cable provided (see Section 5.2.2).

Switch on the Optima unit using the power switch on the rear. The motor will start immediately, and the buzzer will sound while the unit starts up. Switch on the refrigeration unit using the power switch on the front of the unit. The equipment will start to control at the set temperature

5.2 Using the equipment

5.2.1 Product description, refrigeration unit front panel (grille removed)

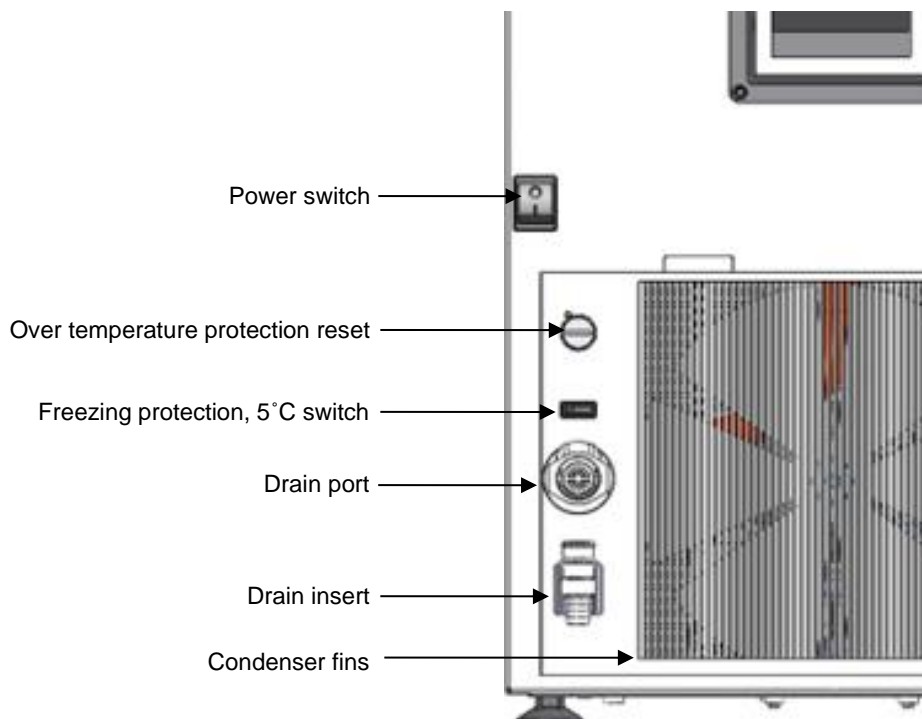

The over temperature protection reset: protects the unit from overheating by the over temperature cut-out. This will be actuated when the working fluid is raised above between 110°C and 120°C. The unit can be reset by waiting for the liquid to cool below 100°C, then unscrewing the black cap and pushing in the revealed button.

The freezing protection switch uses a low temperature thermostat to ensure the working fluid never drops below 5°C. With the switch in the depressed/in position the cooling will be switched off by a low temperature protecting thermostat. If water is used in the bath this will prevent it from freezing. In the out/off position the thermostat is bypassed allowing the unit to run at temperatures below 5°C.

The drain port and insert allow convenient emptying of the refrigeration bath. To drain the unit first remove the drain insert from the holder and connect a suitable length of hosing with a bore of 12.7mm (½") to the drain insert. Have the non connected end of tubing in a receptacle, suitable for the liquid to be drained. Push the drain insert into the drain port and let the liquid drain. To release the drain insert push down the grey button on the drain body and extract the drain insert. Liquid to be drained should not be below 10°C or above 50°C.

5.2.2 Refrigeration, rear panels

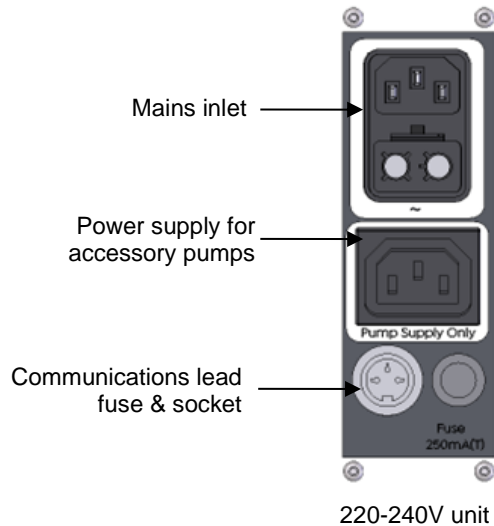

5.2.3 Using the Optima heating circulator

The R unit series are designed for use with the Grant Optima heating circulator range consisting of four models T100, TC120, TX150 and TXF200. Previous G series Optima heating circulators can be used, but may require an alternative bridge plate for mounting the Optima unit. Please contact the Grant instruments technical support team for information.

For full instructions on the functionality and operation of the Optima unit please consult the following applicable manuals:

- 30423 – T100/TC120 Operating manual
- 30424 – TX150/TXF200 Operating manual.

Please read the entire manual to ensure safe operation.

6.0 Technical specifications

6.1 Operating conditions

Ambient temperature range	5 to 40°C
Altitude above sea level	Up to 2,000m (6,500ft)
Operating environment	Indoor use only
Maximum relative humidity	80% RH up to 31°C decreasing to 50% RH at 40°C

6.2 Electrical details

Mains supply: 230V @ 50Hz
 Pollution degree: 2
 Installation category: II

Mains supply voltage fluctuations are not to exceed $\pm 10\%$ of the nominal supply voltage.

6.3 Specification

Specification	R4	
Typical cooling power at an ambient of 20°C	@ 20°C	900W
	@ 0°C	500W
	@ -10°C	300W
	@ -20°C	180W
	@ -30°C	40W
Heater power	1.8kW	
Stability (DIN 12876)	$\pm 0.1^\circ\text{C}$	
Uniformity (DIN 12876)	$\pm 0.1^\circ\text{C}$	
Settable temperature range	-50°C to 150°C	
Working temperature range	-30°C to 100°	
Refrigerant charge R290	190gm	
Tank capacity	20L	
Top opening	230/305mm	
Liquid depth min/max	80/140mm	
Drain	Yes	
Switchable refrigeration	Yes	
Safety 100°C limit	Cut-out	
Safety freezing protection	5°C thermostat & switch	
Safety (high pressure)	27 Bar	
Max current consumption	3.5A	

7.0 Technical Tips

7.1 Which water should you use in your equipment tank?

For the long-term reliability of the equipment it is important to use oxygenated water that is free from ions and minerals that can cause corrosion of stainless steel. We recommend the use of distilled water and de-ionised water from modern ion exchange systems that do not use salt back flushing to regenerate the ion-exchange cartridges.

Stainless steel is protected from corrosion by a layer of chromium oxide. If the layer is damaged, oxygen present in water can reform the oxide layer. If the water is still or de-oxygenated, and the oxide layer is damaged, ions can corrode the stainless steel tank. If a water bath has been unused for some time, or water boiled, we recommend changing to fresh distilled water or correct de-ionised water.

Water normally contains calcium or magnesium ions. De-ionised water has most ions removed as indicated by its conductivity level; the purer the water the lower the conductivity. It is important to use only de-ionised water from an ion exchange system with replaceable cartridges. Do not use de-ionised water generated from an ion-exchange system that incorporates a salt back-flush system to regenerate the ion-exchange resin as this can leave sodium ions that are very corrosive to stainless steel.

7.2 How to prevent rust in equipment tanks

Most Grant tanks, as well as immersed parts, are made from type 304 stainless steel, an extremely versatile general purpose grade of stainless steel. It is the excellent forming characteristic that has made this grade dominant in the manufacture of laboratory and industrial water baths, as well as domestic sinks and saucepans. Type 304 stainless steel is highly suitable for applications where hygiene is important; it exhibits good heat resistance and excellent resistance to corrosion.

However, despite resistance to general surface corrosion, stainless steel is susceptible to specific types of corrosion, in particular pitting (small pin hole style corrosion) and stress corrosion cracking. It can also undergo general corrosion in specific environments, such as one containing hydrochloric or sulphuric acids.

Stainless steel is protected by its high content of alloying elements, primarily chromium and nickel. Chromium is the most important with respect to corrosion resistance, although the nickel assists in allowing the chromium to do its job. The chromium forms an oxide layer on the surface of the steel, which inhibits further oxidation. This layer adheres extremely well to the metal substrate, but it is essential that it remains intact, and must be protected from various forms of damage.

If the surface chromium oxide layer becomes damaged, oxygen present in water can partially reform the oxide layer, so it is advisable to ensure that water is always fresh and well oxygenated. Baths that will be out of use for an extended period should be emptied, and all moisture should be wiped from the bottom of the tank.

In some cases a brown layer may appear on the surface of a stainless steel tank. In most of these cases this is not rust, but it may be a surface deposit of minerals from the local water supply, or ferrous particles or salts that have fallen into the tank. These surface deposits can usually be removed by using a household cleaner such as Duraglit or Silvo metal polish.

7.3 How to prevent algae and bacteria?

Water baths provide the ideal environment for the growth of micro-organisms. If left uncontrolled the growth of these organisms can result in a range of serious problems and health risks from pathogenic bacteria.

The growth of algae on the surface of parts will cause biofouling which can reduce performance.

Micro-organisms that produce acidic metabolic by-products can cause bio-corrosion by depolarisation of metal surfaces.

There are a number of biocides available on the market.

8.0 Warranty information

When used in laboratory conditions according to this manual, this product is guaranteed for THREE YEARS against faulty materials or workmanship.

Extended warranty for years four and five can be purchased by contacting our sales department at labsales@grantinstruments.com.

9.0 Maintenance and service

9.1 Routine maintenance

The refrigerated bath contains a flammable refrigerant:



- Do not use mechanical devices or other means to accelerate defrosting: either turn the equipment off or set it to ambient temperature and wait until all the ice has melted.
- Do not damage the refrigerant circuit.

The over-temperature cut-out on the heating circulator should be checked periodically by turning the over-temperature dial with a screwdriver anticlockwise until the alarm is triggered. The equipment will sound a buzzer and “Over temperature Alarm” will be shown on the display. The over-temperature dial should then be turned to 10°C above liquid temperature and the heating circulator powered off and back on to confirm that the cut-out can be reset correctly. If the alarm is triggered when the value indicated on the over-temperature dial is more than 10°C below the current temperature as indicated by the main display, then the equipment should be checked by a competent person. After performing this check, reset the overtemperature cut-out to the required level for normal operation (see 5.1.3).

The float liquid level protection should also be checked periodically by lowering the level of liquid in the bath and noting that the unit cuts out with the top turn of the heater still immersed in the liquid.

When hoses are fitted to the pump they should be inspected periodically and replaced as necessary to avoid hose failure.

No other routine maintenance is required.

9.2 Cleaning

Regular maintenance of the equipment unit is important to allow the equipment to perform to its specification and is required for warranty validity.

The removable grille of the refrigeration unit enables easy access to the condenser for cleaning. Cooling power will be reduced if the fins become clogged with dust. The condenser fins (see section 5.2.1) should be examined monthly and, if necessary, use a vacuum cleaner nozzle and soft brush to remove the dust. Take care not to damage the condenser fins during cleaning. Always replace the condenser grille following cleaning



Allow the equipment to cool before cleaning the condenser fins



Unplug the equipment from the mains before commencing cleaning

Clean the outside of the equipment with a damp cloth, using water only. Do not use chemical cleaning agents. Before using any other cleaning or decontamination method, check with Grant Instruments or your local representative to make sure that the proposed method will not damage the equipment.

To aid cleaning the heating circulator can be removed from the refrigerated bath. Unfasten the thumbscrews on the top of the refrigerated unit (see 4.2) and lift the heating circulator and top plate.

Scale on immersed parts can be removed using chemical de-scaling products designed for use on equipment that has metal parts. De-scaling products may be toxic and manufacturer's instructions should always be followed

9.3 Fuses

The refrigeration unit has externally accessible fuses that can be changed by a qualified technician. Disconnect the unit from the power supply socket. Remove the IEC power plug from the rear of the unit. Press down the fuse drawer catch and pull out. Check fuses and if necessary replace. Push the fuse drawer back in until fully engaged and replace the IEC plug.

Replacement fuses must be 1.25" x 0.25" anti surge ceramic type with the rating defined in the following table:

R unit	Fuse rating
R4R	5AT

Fuse replacement should only be carried out by a competent person.

9.4 Replacing the mains cord

This equipment must only be used with an appropriately approved cord set acceptable for the country in which the equipment is intended to be used.

The mains cord set must be suitably rated for the equipment it is intended to be used with, refer to the equipment rating label for further details.

No user replaceable parts, if the cord set is damage do not operate the equipment, disconnect from the supply immediately and contact Grant Instruments for replacement or your authorised service agent.

Guidance information table

Country	Cord type	Mains Plug	Appliance coupler
UK	H05VV-F 3G1.5mm ² , 300/500V 90°C	BS 1363	IEC 60320, Type C20
Europe		CEE 7/7	IEC 60320, Type C20

9.5 Routine safety tests

If routine tests are to be made, we recommend a test of the integrity of the protective earth conductor and an insulation test at 500V DC. Routine flash tests are not recommended for any electrical equipment, because repeated high voltage tests degrade insulation materials.

9.6 Disposal



The refrigerated bath contains flammable refrigerant gas which must NOT be discharged into the atmosphere. At the end of the equipment's working life, either have the gas removed safely by using refrigerant recovery equipment or return the equipment to Grant Instruments for disposal.

9.7 Service

If service is required, switch off the unit and contact Grant Instruments or your local representative for repairs.

Please note, all returned units must be accompanied by a Return Materials Authorisation (RMA) number, obtainable by contacting the Grant service department (details below).

Service Department
Grant Instruments (Cambridge) Ltd
Evolution House
Unit 2, Durham Way
Royston Gateway
Royston
SG8 5GX
UK

Tel: +44 (0) 1763 260 811
E-mail: labservice@grantinstruments.com

10.0 Optional accessories

10.1 Alternative pump

A pump comes as standard on Optima models TC120, TX150 and TXF200. If greater head (pressure) is required you can choose from two accessory pumps and the appropriate pump lid. Add L to pump part numbers for 120V (60Hz) versions. See the Grant website at www.grantinstruments.com for full technical specifications.

Pump Product	Description
VTP1	Max head pressure: 1000mBar Max flow rate: 9 L/min
VTP2	Max head pressure: 1700mBar Max flow rate 12 L/min
17927	Pump lid for LTC2

A full listing of product accessories and options is available in the Grant Scientific Reference Catalogue (a copy of which is available upon request) and on the Grant website at www.grantinstruments.com.

11.0 Troubleshooting

Symptom	Possible cause	Action required
Equipment fails to cool	Compressor overheated causing internal over-temperature thermostat to operate	Wait for compressor to cool, when thermostat will reset and compressor will switch on again.
Equipment failing to cool below 5°C	Freezing protection switch is on and is preventing further cooling	Switch off freezing protection (see section 5.2.3).
Equipment not cooling at higher temperatures	Over temperature protection switch has tripped	Refrigeration unit may have temperatures in excess of 100°C. Leave the unit to cool and reset (see section 5.2.3)
Cooling performance reduced	Condenser fins clogged	Carry out routine cleaning (see section 9.1)

For any other errors or service requests, please contact Grant Instruments service department.

12.0 Contact Grant Instruments

At Grant we are continuously trying to improve the performance we offer our customers. If you have any feedback on Grant's products or services we would like to hear from you. Please send all feedback to:

Quality Manager
Grant Instruments (Cambridge) Ltd
Evolution House
Unit 2, Durham Way
Royston Gateway
Royston
SG8 5GX UK

Tel: +44 (0) 1763 260 811
E-mail: support@grantinstruments.com

13.0 Compliance

Waste Electrical and Electronic Equipment (WEEE)



This product marked with the crossed-out wheeled bin symbol indicating it must not be disposed of with unsorted waste. Safe recycling of WEEE helps conserve natural resources and protect human health.

Grant Instruments complies fully with the UK Waste Electrical & Electronic Equipment (WEEE) regulations 2013. We are a member of the B2B compliance scheme (Scheme Approval Number WEE/MP3338PT/SCH), which handle our WEEE obligations on our behalf. Grant Instruments have been issued with a unique registration number by the Environmental Agency, this reference number is WEE/GA0048TZ.

For information regarding WEEE collections in the UK please contact our B2B Compliance Scheme directly on 01691 676 124 or www.b2bcompliance.org.uk

In the EU, Grant Instruments complies with WEEE Directive 2012/19/EU. Contact your local equipment supplier for WEEE collections.

Restriction of substances hazardous to health (RoHS)

This product complies with the requirements of the UK Restriction of the Use of Certain Substances in Electrical and Electronic equipment Regulations 2012 and the EU RoHS Directive (2011/65/EC including 2015/863). This means the products are free of Lead and other hazardous substances covered by the directive.

Electrical safety and electromagnetic compatibility

This product complies with the requirements of the UK Electrical Equipment (Safety) Regulations 2016 and the European Union Low Voltage Directive (2014/35/EC) for Electrical safety.

This product complies with the requirements of the UK Electromagnetic Compatibility Regulations 2016 and the European Union EMC directive (2014/30/EC).

Refrigerant F-Gas regulations

The R4 refrigeration unit is hermetically sealed equipment containing HC refrigerant R290.

Refrigerant charge: 0.19 Kg

CO2 equivalent: 0.0006 Tonnes

Dispose of refrigeration according to local regulations

REACH Regulation

This product does not contain any Substances of Very High Concern (SVHCs) at greater than 0.1% that have to be identified in accordance with Regulation (EC) No 1907/2006 and therefore does not have an entry in the SCIP database

Notes

Notes



Grant Instruments (Cambridge) Ltd

Evolution House
Unit 2, Durham Way
Royston Gateway
Royston
SG8 5GX
UK

Tel: +44 (0) 1763 260811
salesdesk@grantinstruments.com
www.grantinstruments.com

Representative in the European Union

Grant Instruments Europe B.V
Strawinskylaan 411
WTC, Tower A, 4th Floor
1077 XX AMSTERDAM
THE NETHERLANDS

grant@eu.grantinstruments.com